



Lab 745/845/945

Oxygen/pH-ORP-ISE/conductivity meter

SI Analytics

a xylem brand

Wichtige Hinweise:

Die Gebrauchsanleitung ist Bestandteil des Gerätes. Vor der ersten Inbetriebnahme bitte sorgfältig lesen, beachten und anschließend aufbewahren. Aus Sicherheitsgründen darf das Gerät ausschließlich für die beschriebenen Zwecke eingesetzt werden. Bitte beachten Sie auch die Gebrauchsanleitungen für eventuell anzuschließende Geräte.

Alle in dieser Gebrauchsanleitung enthaltenen Angaben sind zum Zeitpunkt der Drucklegung gültige Daten. Es können jedoch von SI Analytics GmbH sowohl aus technischen und kaufmännischen Gründen, als auch aus der Notwendigkeit heraus, gesetzliche Bestimmungen der verschiedenen Länder zu berücksichtigen, Ergänzungen an dem Gerät vorgenommen werden, ohne dass die beschriebenen Eigenschaften beeinflusst werden.

Important notes:

The operating manual is part of the product. Before initial operation of the unit, please carefully read and observe the operating instructions and keep it. For safety reasons the unit may only be used for the purposes described in these present operating instructions. Please also observe the operating instructions for the units to be connected

All specifications in this instruction manual are guidance values which are valid at the time of printing. However, for technical or commercial reasons or in the necessity to comply with the statutory stipulations of various countries, SI Analytics GmbH may perform additions to the unit without changing the described properties.

Instructions importantes:

Le manuel d'utilisation fait partie du produit. Prière de lire et d'observer attentivement le mode d'emploi avant la première mise en marche de l'appareil, et de le conserver. Pour des raisons de sécurité, l'appareil ne pourra être utilisé que pour les usages décrits dans ce présent mode d'emploi. Nous vous prions de respecter également les modes d'emploi pour les appareils à connecter.

Toutes les indications comprises dans ce mode d'emploi sont données à titre indicatif au moment de l'impression. Pour des raisons techniques et/ou commerciales ainsi qu'en raison des dispositions légales existantes dans les différents pays, SI Analytics GmbH se réserve le droit d'effectuer des suppléments concernant l'appareil pour séries de dilution qui n'influencent pas les caractéristiques décrits.

Instrucciones importantes:

El manual de instrucciones forma parte de producto. Antes de la operación inicial de aparato, lea atentamente y observe las instrucciones de operaciones y guárdelas. Por razones de seguridad, el aparato sólo debe ser empleado para los objetivos descritos en este manual de instrucciones. Por favor, observe las instrucciones de operación para las unidades a conectar.

Todas las especificaciones en este manual de instrucciones son datos orientativos que son válidos en el momento de la impresión. No obstante, por motivos técnicos o comerciales, o por la necesidad de respetar las normas legales existentes en los diferentes países, SI Analytics GmbH puede efectuar modificaciones del aparato sin cambiar las características descritas.

TABLE OF CONTENTS		Page
1	Technical Specifications of the meter Lab 745 / 845 / 945	41
1.1	Intended Use	41
1.2	User qualification	41
1.3	Specifications	41
1.4	Warning and safety information	43
2	Set up and Commissioning	44
2.1	Scope of delivery	44
2.2	Unpacking and Setup	44
2.3	Power supply	44
3	Device description.....	45
3.1	Measuring inputs	45
3.2	Controls	46
3.3	Display	47
3.4	Password protection	47
4	Configuration of basic settings.....	48
4.1	Configuration of the backlight and the contrast.....	48
4.2	Configuration of the password	48
4.3	Configuration of the clock.....	49
4.4	Configuration of the language	49
4.5	Configuration of the switch-off time.....	49
5	Data logger.....	50
5.1	Menu structure data logger	50
5.2	Interval.....	50
5.3	Automatic	50
6	Info.....	51
6.1	General.....	51
6.2	Menu structure info.....	51
7	Interface HMG USB.....	51
8	Meter Lab 745.....	52
8.1	Areas of use	52
8.2	Basic model.....	52
8.3	Oxygen sensor Ox1113T	52
8.4	Menu structure (CONF) Lab 745.....	53
8.5	Configuration Lab 745	54
8.5.1	Basic settings	54
8.5.2	Configuration of the fixed temperature.....	54
8.5.3	Configuration of "Main display"	54
8.6	Calibration method Oxygen.....	55
8.6.1	Menu structure	55
8.6.2	Calibration	55
9	Meter Lab 845.....	57
9.1	Areas of use	57
9.2	Basic model.....	57
9.3	pH sensor.....	57
9.4	Menu structure (CONF) Lab 845.....	58
9.5	Configuration Lab 845	59
9.5.1	Basic settings	59
9.5.2	Configuration of the fixed temperature.....	59
9.5.3	Configuration of the sensor type	59
9.6	Calibration method pH.....	60
9.6.1	Menu structure	60
9.6.2	Calibration	60

9.7	Calibration method OPR	62
9.7.1	Menu structure	62
9.7.2	Calibration	62
9.8	Calibration method ISE	63
9.8.1	Menu structure	63
9.8.2	Calibration	63
10	Meter Lab 945.....	65
10.1	Areas of use	65
10.2	Basic model.....	65
10.3	Conductivity sensor LF435T	65
10.4	Menu structure (CONF) Lab 945.....	66
10.5	Configuration Lab 945	67
10.5.1	Basic settings	67
10.5.2	Configuration of the fixed temperature.....	67
10.5.3	Configuration of the measuring range "M range"	68
10.6	Calibration method Conductivity	69
10.6.1	Menu structure	69
10.6.2	Calibration	69
11	Scope of delivery.....	71
12	Accessories	72
13	Maintenance.....	73
14	Guarantee.....	73
15	Recycling and Disposal	73

Notes about Instructions for Use

These instructions for use are intended to show you the proper and safe handling of the product. For the highest possible safety you must adhere to the listed safety and warning notes in these manual!

The pictograph  has the following meaning:

- Warning of a general danger.
- No-compliance results (can result) in injury or material damage.

 Important information for the use of the device.

 Refers to another part of the operating manual.

Status at time of printing

Advanced technology and the high quality of our products are guaranteed by a continuous development. This may result in differences between this operating manual and your product. We cannot exclude mistakes. We are sure you understand that no legal claims can be derived from the information, illustrations and descriptions.

A potentially more recent version of this manual is available on our internet website at www.si-analytics.com. The German version is the original version and binding in all specifications.

Copyright

© 2016, SI Analytics GmbH

Reprinting - even as excerpts - is only allowed with the explicit written authorization. Printed in Germany.

1 Technical Specifications of the meter Lab 745 / 845 / 945



1.1 Intended Use

The meter Lab 745 / 845 / 945 is intended for the measurement and documentation of analysis parameters while adhering to the technical specifications. Any use beyond this purpose - as well as your own modifications or expansions - is not in conformity with prohibited.

 When you connect the meter to electro-chemical sensors, their limited product life and natural wear and tear must be taken into consideration, as these can lead to malfunctions of the meter. The user must take the appropriate measures to limit the dangerous effects of such malfunctions

1.2 User qualification

The meter was developed for measurements in analysis technology. It is assumed, based on their professional training and experience, that the operator/user and the maintenance personnel are familiar with the specifications of analysis meters, can handle chemicals in a safe manner, e.g. during maintenance work on the electrodes/sensors and that they can estimate the hazards caused by these. The operator must ensure that the national laws and guidelines regarding occupational safety, accident prevention and handling of chemicals are adhered to.

 Please observe the general (see  1.4) and all in the text additionally placed warnings and safety notes!

1.3 Specifications

Translation of the legally binding German version

(Release: 18. January 2016)

CE sign:  EMC compatibility according to the Council Directive: 2004/108/EG;
applied harmonized standards: EN 61326-1:2006
Low-voltage directive according to the Council Directive 2006/95/EG
Testing basis EN 61 010, Part 1

Contry of origin: Germany, Made in Germany

General information (Lab 745 / 845 / 945)

Housing:

Material: Aluminum desk housing IP 40/DIN EN 60529
Dimensions: 145 x 185 x 55 mm (W x H x D)
Weight: approx. 750 g (incl. power supply and stand)

Display: graphic LCD display, 128 x 64 pixels, backlight

USB Interface: USB with "Z 613", galvanically isolated

Data logger: stores up to 4,000 data sets (date, time, main measured value, secondary measured value, measuring temperature)

EMV: as per EN 61326; class B

Climate: Ambient temperature: 0 ... + 55 °C for operation
Ambient temperature: - 25 ... + 65 °C for storage and transport
Humidity: max. <95 % (no condensation)

Ambient conditions:

 Do not used in hazardous locations!

Power supply:

By external power supply 5 V DC of 100 - 240 V; 50/60 Hz; power input: 5 Watt

 Use only the power supply Z 612 (Mo. VER05US050-JA; input 100-240V~; 50/60Hz; 0,18A; output 5V DC; 1A max.; class II)!

Lab 745

Measurement value:	0 ... 200%; 0 ... 20 mg/l; Temperature: -10 ... 100 °C
Resolution:	0.1 %; 0.01 mg/l; 0.1 °C
Temp. compensation:	automatic with NTC or fixed temperature
Accuracy:	±1 digit, ± 0.5 % of measuring range, T [°C] ± 0.1 (5...50 °C)
Connections:	8-pin flange plug, 4-pin interface USB port
Calibration:	Direct input (rise, B<20°C, B>20°C) Temperature offset One-point Automatic

Lab 845

Measurement value:	pH -2 ... 16; -2000 ... 2000 mV; Temperature: -10 ... 100 °C; ISE 0 ... 30000 ppm
Resolution:	0.01 pH; 1 mV; 1 ppm; 0.1 °C
Temp. compensation:	automatic with Pt 1000 or fixed temperature
Accuracy: (0...100 °C)	pH ± 0,01 (± 2 pH units around the calibration point), U [mV] ± 0,3; T [°C] ± 0,1
Connections:	BNC, 2x banana plug (4 mm), 4-pin interface USB port
Calibration:	Direct input (rise, asymmetry) Temperature offset Two-point Automatic

The Lab 845 offers the following buffer sets for automatic calibration:

NBS standard buffering solution as per DIN 19266:	pH-Wert bei 25 °C	1.68 / 4.01 / 6.86 / 9.18 / 12.45
Technical buffering solution as per DIN 19267:	pH-Wert bei 25 °C	1.09 / 3.06 / 4.65 / 6.79 / 9.23
Merck buffering solution:	pH-Wert bei 20 °C	4.00 / 7.00 / 9.00
Mettler Toledo buffering solution:	pH-Wert bei 25 °C	1.679 / 4.003 / 7.002 / 10.013

Lab 945

Measurement value:	0 ... 200 µS/cm; 0 ... 2000 µS/cm; 0 ... 20 mS/cm; 0 ... 500 mS/cm; automatic measuring range switching
TDS:	0 ... 200 mg/l; 0 ... 2000 mg/l; 0 ... 20 g/l; 0 ... 500 g/l
Salinität:	0 ... 70 g/kg; Temperature: -10 ... 100 °C
Resolution:	0.1 µS; 1 µS; 0.01 mS; 0.1 mS; 0.1 °C
Temp. compensation:	automatic with NTC or fixed temperature
Accuracy:	±1 digit, ± 0.5 % of measuring range, T [°C] ± 0.1 (5...50 °C)
Connections:	8-pin flange plug, 4-pin interface USB port
Calibration:	Direct input (cell constant, temperature compensation, cable offset, TDS factor) Temperature offset One-point Automatic

1.4 Warning and safety information

The meter Lab 745 / 845 / 945 has the protection class III.

It was manufactured and tested according to DIN EN 61 010, Part 1, "**Protective Measures for electronic measurement devices and control devices**" and has left the factory in an impeccable condition as concerns safety technology. In order to maintain this condition and to ensure safe operation, the user should observe the notes and warning information contained in the present operating instructions. Development and production is done within a system which meets the requirements laid down in the DIN EN ISO 9001 standard.

 For reasons of safety, the meter Lab 745 / 845 / 945 and the power supply (Z 612) must be opened by authorised persons only; this means, for instance, that work on electrical equipment must only be performed by qualified specialists. **In the case of nonobservance of these provisions the titrator and the power supply may constitute a danger: electrical accidents of persons or fire hazard!** Moreover, in the case of unauthorised intervention in the titrator or the power supply, as well as in the case of negligently or deliberately caused damage, the warranty will become void.

 Prior to switching the device on it has to be ensured that the operating voltage matches the mains voltage. The operating voltage is indicated on the power supply. **Nonobservance of this provision may result in damage to the titrator and the power supply, or in personal injury or damage to property!**

 **If it has to be assumed that safe operation is impossible, the meter has to be put out of operation and secured against inadvertent putting to operation!** Switch the meter off, pull plug of the mains cable out of the power supply, and remove the meter from the place of work.

Examples for the assumption that a safe operation is no longer possible,

- if the package is damaged,
- if the meter shows visible damages,
- if the power supply (Z 612) shows visible damages,
- if the meter does not function properly,
- if liquid has penetrated into the casing.
- if the meter has been altered technologically or if unauthorized personnel tried or succeeded to open the instrument as attempt to repair it.

In case that the user operates such a device, all thereof resulting risks are on the user.

 The meter must not be stored or operated in humid rooms.

 **The relevant regulations regarding the handling of the substances used have to be observed:** The Decree on Hazardous Matters, the Chemicals Act, and the rules and information of the chemicals trade. It has to be ensured on the side of the user that the persons entrusted with the use of the meter are experts in the handling of substances used in the environment and in titrator or that they are supervised by specialised persons, respectively.

 Use only the sensors, sensor cables and interface cables recommended by the manufacturer. The notes and statements in the respective user manuals and data sheets apply to the use of the sensors and fittings.





 The device does not contain any components that need to be replaced and must only be opened for repair by the manufacturer's technicians.

If in doubt, please contact the supplier.

2 Set up and Commissioning

2.1 Scope of delivery

The scope of delivery is shown on the included packing list.

-  There is a detailed list of the individual sets in  chapter **11 Scope of delivery**
-  Accessories can be found in  chapter **12 Accessories**



2.2 Unpacking and Setup

The meter and all accessories were carefully inspected for function and size accuracy at the factory. Please make sure that you also remove all of the small additional parts from the packaging.

The meter can be set up on any even surface.

 The safety of the system, in which the device will be integrated, is the responsibility of the installer.

 If the meter is transported from a cold into a warm environment, there can be malfunctions in the device caused by condensate. In this case, you have to wait until the device temperature and the room temperature have reached a balance before you start the meter.

 The flawless function and operational safety of the meter can only be warranted under those climate conditions specified in  **1.3 "Specifications"**.

2.3 Power supply

The meter is delivered ready to operate with a 5 DC power supply.

 Position the power supply where it is easily accessible so that the meter can be separated from the power at any time.

Check the power supply regularly. If the power supply is damaged it must be promptly replaced by an undamaged unit.

 Use only the power supply Z 612 (Mo. VER05US050-JA; input 100-240V~; 50/60Hz; 0,18A; output 5V DC; 1A max.; class II)!

Applies only to the Lab 745:

 After an interruption in the continuous polarization (device separated from power supply or similar), you must observe the waiting period for calibration. We also recommend a new calibration.

3 Device description

3.1 Measuring inputs

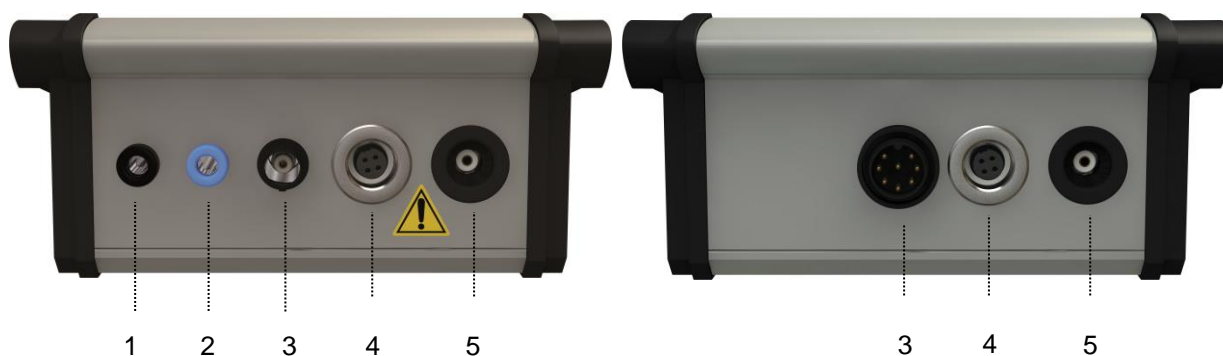

Fig. 1 Lab 845

Fig. 2 Lab 745 and Lab 945

- 1) Sensor connection (black) Reference
- 2) Sensor connection (blue) Temperature
- 3) Sensor connection
- 4) USB port
- 5) Main Supply

On the front of the meter, there are special connectors to connect the sensor and a USB interface cable.

⚠ Use only the sensors, sensor cables and interface cables recommended by the manufacturer. The notes and statements in the respective user manuals and data sheets apply to the use of the sensors and fittings. As the measuring system is intended for the measuring of analysis parameters you must keep in mind that the sensors must be calibrated and maintained regularly.

⚠ The measuring input must be free of potentials and must not be connected to power conducting potentials. All inputs must only be operated with the proper sensors. The direct connection of different signals is prohibited!

i In order to protect the connections from the ingress of moisture and the resulting corrosion, you should always leave the sensor plugged into the meter.

⚠ Please note the switches when connecting to other devices (e.g. via USB interface). Internal connections in other devices (e.g. connecting GND to earth) can lead to impermissible voltage potentials that can impair the function of the meter itself or other devices or can even destroy them.

i Use only interface cable Z 613 to transfer data from the meter to the PC. This cable is not included in the delivery and must be purchased separately (**📖** chapter **12 Accessories**).

You will find the software here:

<http://www.si-analytics.com/downloads/software-updates.html>

3.2 Controls

The meter has an intuitive clear text menu structure.

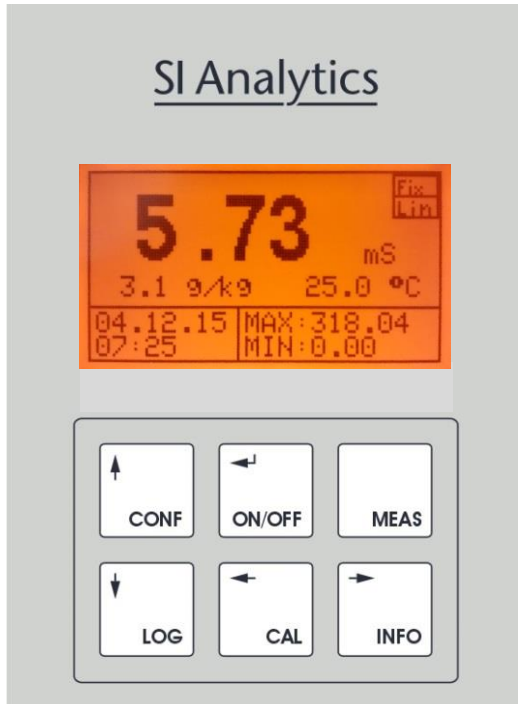









Fig. 3

	 CONF	 LOG	 ON/OFF	 CAL	 MEAS	 INFO
Open menu	Configuration	Data logger	Switching ON/OFF	Calibration	Measuring mode	Information
Navigating the menu	Cursor up	Cursor down	Selection / ENTER	Cursor left	Measuring mode	Cursor right
Change / enter values	Position value +1	Position value -1	Save / confirm value	Cursor left	Measuring mode	Cursor right

 The meter is turned on by pressing (**ON/OFF**). Switching off takes place either automatically after the preset time period has elapsed or by a long (approx. 3 seconds) press of (**ON/OFF**).

Applies only to the Lab 745:

 Even in a switched off state, the O₂ sensor is supplied with the required polarization voltage and is therefore ready to measure as soon as it is switched on.

3.3 Display

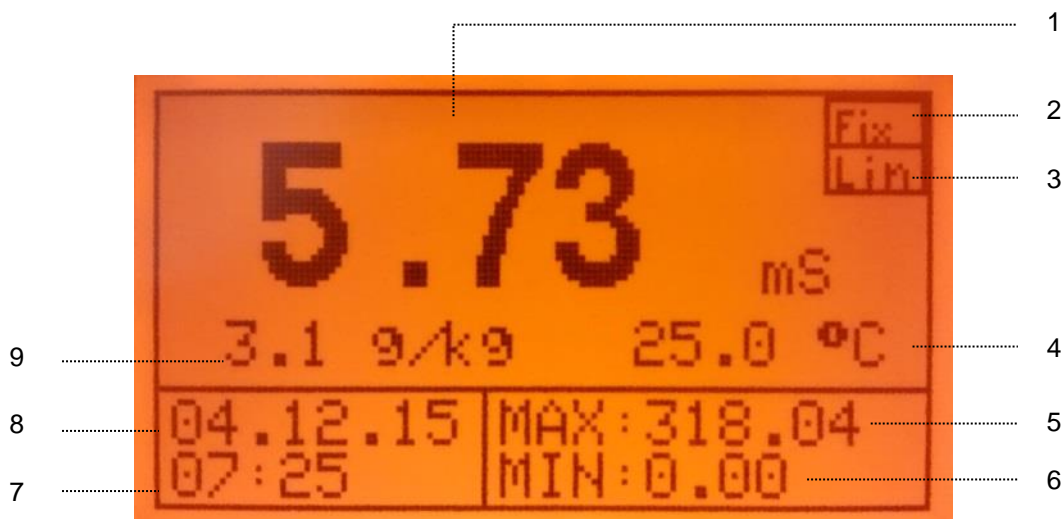

Fig. 4

- 1) Main measured value
- 2) Fixed temperature active
- 3) Temperature compensation (**applies only to Lab 945**)
- 4) Temperature
- 5) **Min.** main measured values
- 6) **Max.** main measured values
- 7) Time
- 8) Date
- 9) Secondary measured value

3.4 Password protection

It's possible to protect the menu items Calibration (**CAL**) and Configuration (**CONF**) by a password. This password can be defined in the menu item (**CONF**) under "**General**" (also see [4.2](#))

i The password to open the individual menus is deactivated when the device is delivered!

Password = 0 (status at time of delivery)

Password > 0 (password inquiry is active – the user is asked for a password))

The password can have up to 4 digits (1 - 9999).

Password configuration:

(**CONF**) > "**General**" > "**Password**" > enter and repeat password.

Via (**INFO**) or (**CAL**) you select the position to change.





Via (**CONF +1**) or (**LOG -1**) you change the position.

(**ON/OFF**) confirms and saves your setting.

(**MEAS**) terminates the entry dialog without transferring the value.

4 Configuration of basic settings

Via (**CONF**) you will get to the menu item "**Configuration**" and then on to submenu item "**General**".

 The entire structure of the menu (**CONF**) is displayed graphically for each meter.
Lab 745 see  **8.4**, **Lab 845** see  **9.4**, **Lab 945** see  **10.4**

Under "**General**", the following device-relevant basic settings can be configured:

Display	→	backlight and contrast
Password	→	Password
Clock	→	Clock
Reset	→	Restart device
Language	→	Language
Time OFF	→	Time until automatic switch-off
Response action	→	Filtering the measured value

4.1 Configuration of the backlight and the contrast

The backlight of the display can be switched on or off on the meter.

Configuration of the lighting:

"**General**" > "**Display**" > "**Backlight**", then select **activate** / **deactivate**.

Configuration of contrast:

"**General**" > "**Display**" > "**Contrast**", then select **low** - **medium** - **high**.

Via (**CONF +1**) or (**LOG -1**) you selected the desired setting.
(ON/OFF) confirms and saves your setting.
(MEAS) terminates the entry dialog without transferring the value.

4.2 Configuration of the password

The menu items calibration (**CAL**) and configure (**CONF**) can be protected by a password.

 The password to open the individual menus is deactivated when the device is delivered!

Password = 0 (status at time of delivery)
 Password > 0 (password inquiry is active, the user is asked for a password)

The password can have up to 4 digits (1 - 9999).

Password configuration:

(**CONF**) > "**General**" > "**Password**" > enter and repeat password.

Via (**INFO**) or (**CAL**) you select the position to change.
 Via (**CONF +1**) or (**LOG -1**) you change the position.
(ON/OFF) confirms and saves your setting.
(MEAS) terminates the entry dialog without transferring the value.

4.3 Configuration of the clock

Configuration of the clock:

"**General**" > "**Clock**", then make the corresponding setting.

Via (**CONF +1**) or (**LOG -1**) you selected the desired setting.

(**ON/OFF**) confirms and saves your setting.

(**MEAS**) terminates the entry dialog without transferring the value.

4.4 Configuration of the language

Configuration of the language:

"**General**" > "**Language**", then make the corresponding setting.

Via (**CONF +1**) or (**LOG -1**) you selected the desired setting.

(**ON/OFF**) confirms and saves your setting.

(**MEAS**) terminates the entry dialog without transferring the value.

4.5 Configuration of the switch-off time

You can set the time on the meter, after which the meter will be switched off automatically.

 The data logger also records while the meter is off, if the data logger has been set up for this.

Configuration of the automatic switch-off time:

"**General**" > "**Switch-off time**", then enter the desired switch-off time.

Via (**CONF +1**) or (**LOG -1**) you selected the desired setting.

(**ON/OFF**) confirms and saves your setting.

(**MEAS**) terminates the entry dialog without transferring the value.

 If the **switch-off time = 0** was selected, the function is deactivated!



5 Data logger

The meter has an integrated ring memory data logger with real-time clock for 4,000 data sets (date, time, main measured value, secondary measured value, measuring temperature).

The saved data can either be viewed directly on the display or read via the USB interface.

(**CONF**) will take you to the menu item "**Configuration**" and on to the submenu item "**Data logger**".

 The entire structure of the menu (**CONF**) is displayed graphically for each meter.

Lab 745 see  8.4, **Lab 845** see  9.4, **Lab 945** see  10.4

5.1 Menu structure data logger

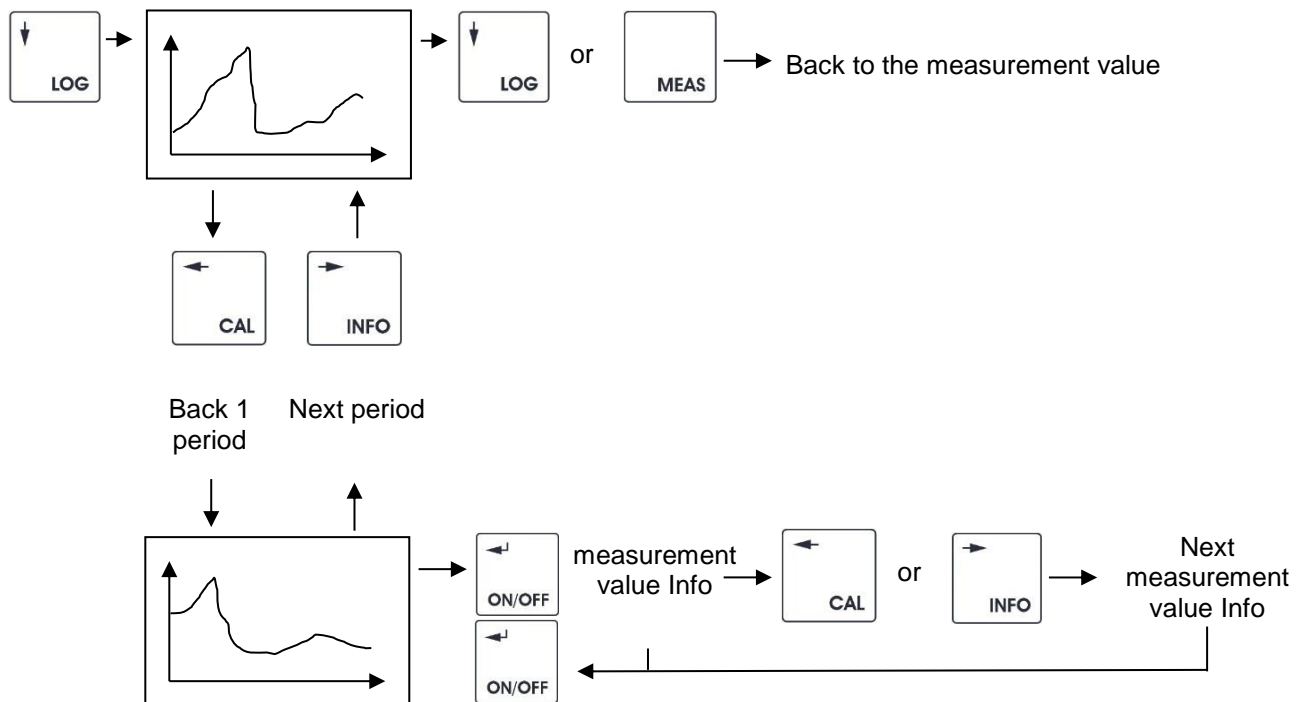

5.2 Interval

You can set up the memory intervals in the submenu point "**Interval**".

Via (**INFO**) or (**CAL**) you select the position to change.

Via (**CONF +1**) or (**LOG -1**) you change the position.

(**ON/OFF**) confirms and saves your setting.

(**MEAS**) terminates the entry dialog without transferring the value.

5.3 Automatic

You can set up the automatic function of the data logger in the submenu item "**Automatic**".

Automatic function "**Off**"> the logger only logs while the device is switched on

Automatic function "**On**"> the logger logs with the device switched on or off
(at the same time the power supply connected)!

 The correct setting of the real-time clock is required for the proper function of the data logger.

 During the reading of the logger data, no further data is recorded!

6 Info

6.1 General

In this menu item, the first page shows the information about the current calibration values and the last calibration time (date).

The second page shows the maximum and minimum values of the main measured value and the time when these values are measured.

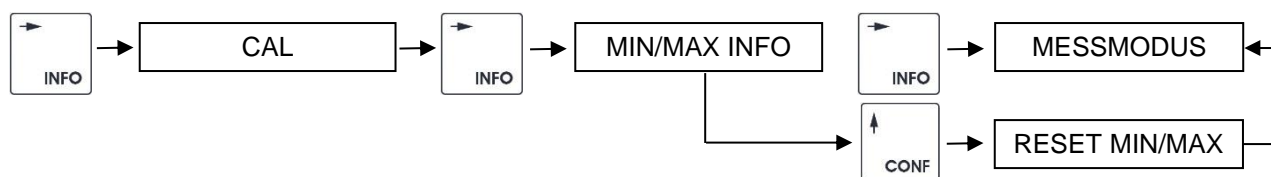

 On this page, you can press the (**CONF**) button to reset the minimum and maximum values.

6.2 Menu structure info



7 Interface HMG USB

The reading of the data logger as well as the configuration of the measuring system can also take place via the software "Labx45pilot".

 Use only interface cable Z 613 to transfer data from the meter to the PC. This cable is not included in the delivery and must be purchased separately ( chapter **12 Accessories**).

You will find the software here:

<http://www.si-analytics.com/downloads/software-updates.html>

8 Meter Lab 745

8.1 Areas of use

The oxygen meter is used to determine of dissolved oxygen as per the German Standard procedures for water, wastewater and mud examination as per DIN EN ISO 5814:2013 and combines the advantages of compact dimensions with the precision and the comfort of a lab meter. It is excellent for the control of the oxygen content in surface water, in wastewater and for the wastewater treatment. Simultaneous oxygen and temperature measurement, high measuring accuracy, multifunction display, simple air calibration, integrated data logger and the robust aluminum housing are trademarks of this meter.

8.2 Basic model

The basic model meter Lab745 is delivered with the sensor Ox1113T. This combination meets the requirements for the determination of the dissolved oxygen; electro-chemical procedure as per DIN EN ISO 5814:2013. If it is connected to the sensor, the meter will also capture the mass concentration of the dissolved oxygen in mg/l oxygen and the oxygen saturation index (% saturation) and the temperature.

8.3 Oxygen sensor Ox1113T

The sensor is based on an amperometric measuring cell with a Pt cathode as an indicator electrode and an Ag/AgCl anode as a counter electrode. Both electrodes, including the cell electrolyte, are separated from the measuring medium by a mostly chemically resistant, but molecular oxygen permeable membrane. With this, the interfering components in the measured material cannot impair the functionality of the electro-chemical measuring cell. With the polarization voltage of approx. 700 mV between the Pt cathode and the Ag/AgCl anode, the oxygen diffused from the oxygen-containing material through the polymer membrane is reduced cathodically to hydroxide ions. The oxidation causes an equivalent number of silver ions on the anode, which react with the chloride ions of the electrolyte solution. The flowing diffusion stream is proportional to the oxygen partial pressure in the sensor. The oxygen sensor consists of a shaft and a base, including electrode system and membrane head. The base contains a platinum cathode and Ag/AgCl: anode plus a temperature sensor. The oxygen permeable polymer membrane is integrated into the membrane head. The extremely stable multi-layer membrane used here ensures reliable measurements over long time periods without exchanging the membrane head and electrolyte.

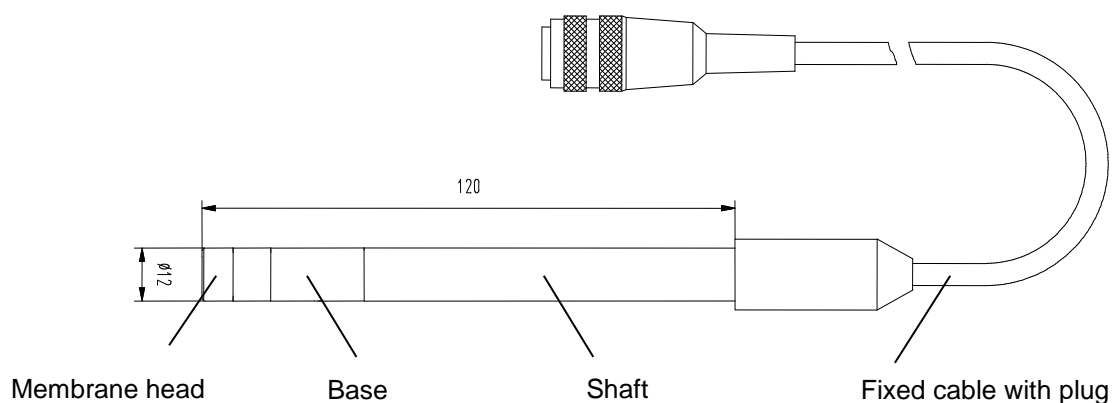

8.4 Menu structure (CONF) Lab 745

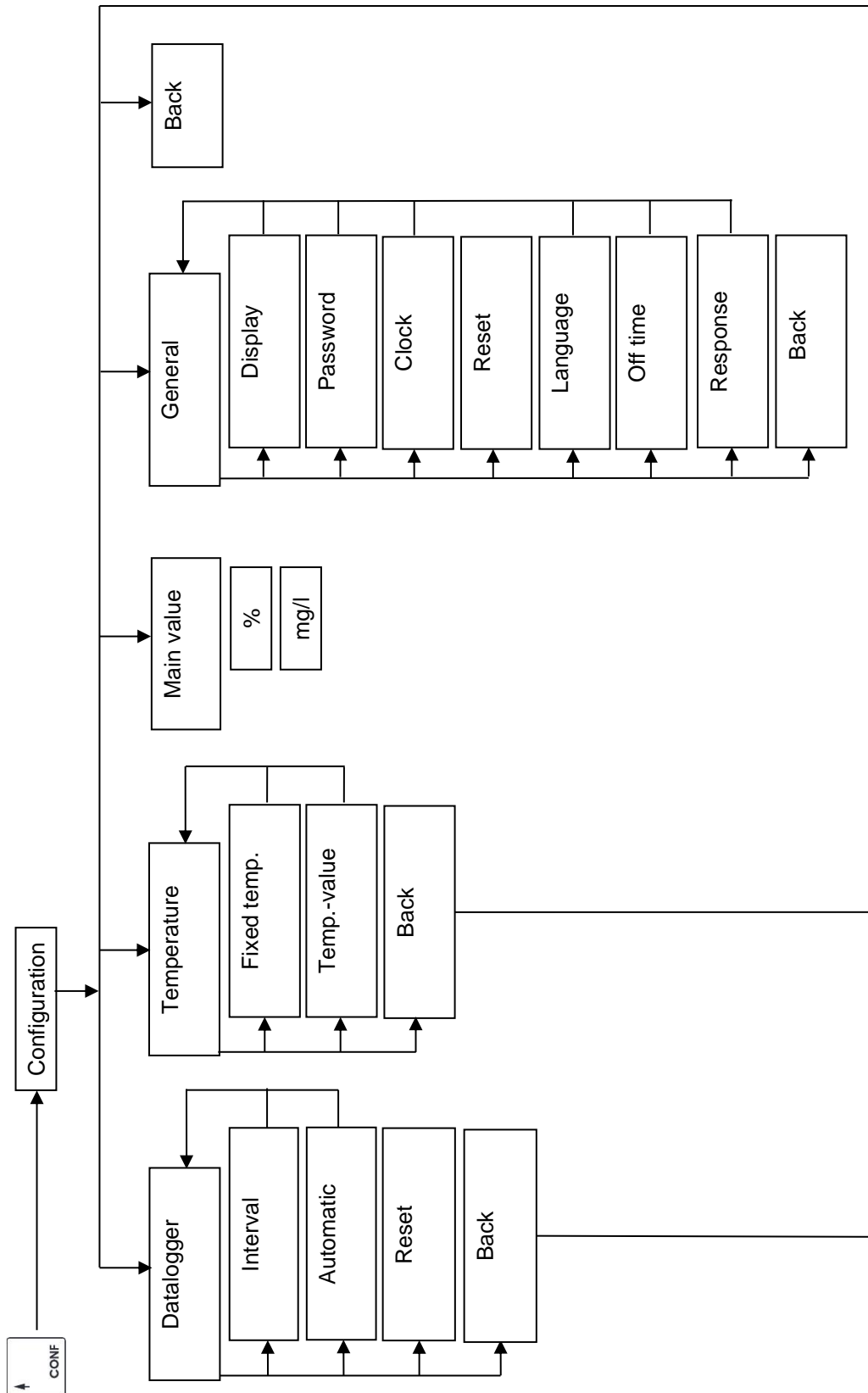



8.5 Configuration Lab 745

8.5.1 Basic settings

Via (**CONF**) you will go to the menu item "**Configuration**".

 The entire structure of the menu (**CONF**) is displayed graphically in  **8.4**.

The following device-relevant basic settings can be configured:

data logg.	→	Data logger ( Chapter 5)
temperature	→	Temperature
main value	→	main value
general	→	General ( Chapter 4)

8.5.2 Configuration of the fixed temperature

As the oxygen measured value timer is temperature-compensated, the temperature of the measuring and calibration media must be measured or saved as a fixed temperature.

 If the fixed temperature is activated, it is used for temperature compensation.

> The message "**FIX**" will appear in the top right side of the display.

> Configuration of the fixed temperature:

"**Temperature**" > "**Fixed temperature**" >, select **activate** / **deactivate**
 "**Temperature**" > "**Temp. value**" >, select the fixed temperature value.

Via (**INFO**) or (**CAL**) you select the position to change.

Via (**CONF +1**) or (**LOG -1**) you change the position.

(**ON/OFF**) confirms and saves your setting.

(**MEAS**) terminates the entry dialog without transferring the value.

8.5.3 Configuration of "Main display"

The main measured value and the secondary measured value can be switched on the meter.

 If not specified otherwise, the factory setting is the main measured value as the oxygen saturation in % and the secondary measured value is set as the oxygen concentration in mg/l.

> Configuration of the main measured value:

"**Main display**" >, then select the measured value.

	Main measured value	Secondary measured value
%	Saturation in %	Concentration in mg/l
mg/l	Concentration in mg/l	Saturation in %

Via (**CONF +1**) or (**LOG -1**) you selected the main measured value.

(**ON/OFF**) confirms and saves the input value.

(**MEAS**) terminates the entry dialog without transferring the value.

8.6 Calibration method Oxygen

8.6.1 Menu structure

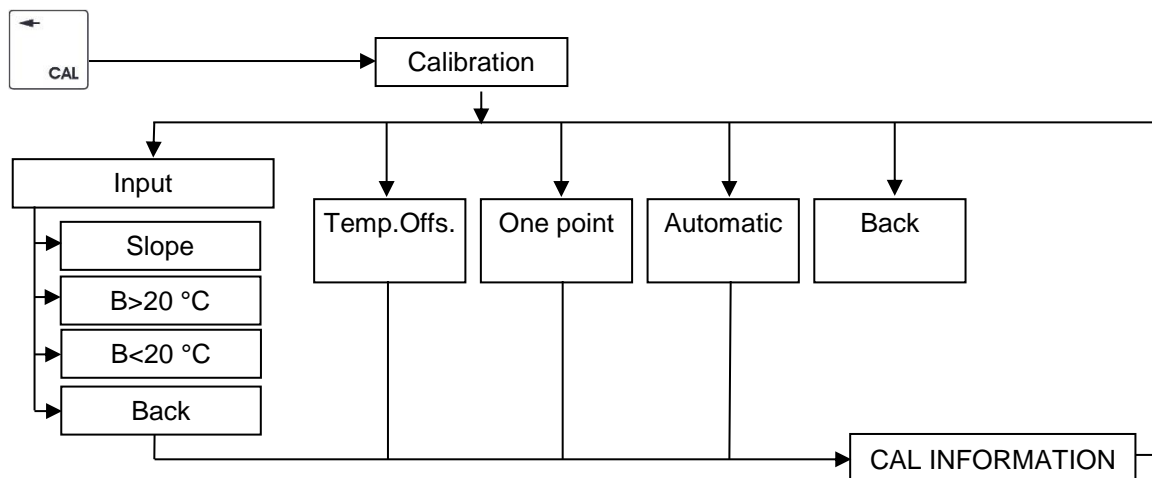

8.6.2 Calibration

Select **(CAL)** to get to the menu item "**Calibration**" and then on to the **Calibration menu**:

> The calibration procedures for the respective sensor type are displayed.

Choose your desired calibration procedure by selecting the respective menu item.



The sensor must be thoroughly cleaned with distilled or deionized water prior to and between every measurement.

Immerse the sensor into the calibration solution and wait until a stable measured value is reached.



Ensure that the calibration medium is mixed properly and watch for the temperature balance.

8.6.2.1 Data input

Under menu item "**Input**", you can enter and change the specific characteristics of the connected sensor, e.g. ones that were previously defined in the lab, individually.

> Select the respective submenu item for which the settings should be changed.

An input dialog will allow you to change the respective calibration/sensor values and their respective limits. If these are not reached or exceeded, there will be an error message, which will ask you to enter a value within these limits.

Via **(INFO)** or **(CAL)** you select the position to change.

Via **(CONF +1)** or **(LOG -1)** you change the position.

(ON/OFF) confirms and saves your setting.

(MEAS) terminates the entry dialog without transferring the value.

8.6.2.2 Temperature offset

Under menu item "**Temp.Offs.**" you can enter an offset for the temperature value.

> Select "**Temp.Offs.**".

An input dialog allows you to set up the offset. This value can be positive or negative.

Via (**CONF +1**) or (**LOG -1**) you selected the desired setting.
(ON/OFF) confirms and saves your setting.
(MEAS) terminates the entry dialog without transferring the value.

8.6.2.3 One point calibration

The measuring signal will be calibrated at this one point by means of a defined oxygen concentration (reference measurement) or a known nominal value, e.g. via an independent procedure or a lab/field device.

> You will be invited to immerse the sensor into the calibration medium (ambient air).

Confirm this dialog with (**ON/OFF**). The currently measured values will be displayed.
 If the measured values (O₂+ Temperature) are in a stable condition, reconfirm by pressing (**ON/OFF**).

> You will be prompted to immerse a nominal value.

Via (**CONF +1**) or (**LOG -1**) you selected the desired setting.
(ON/OFF) confirms and saves your setting.
(MEAS) terminates the entry dialog without transferring the value.

This completes the calibration process. The new calibration value will be saved in the device.

8.6.2.4 Automatic calibration

The automatic calibration of the oxygen sensor is a one point calibration to 102 % and takes place in water vapor saturated ambient air at a temperature of $\geq 5^{\circ}\text{C}$.

 In order to avoid calibration errors caused by vaporization coldness (automatic temperature compensation!), the sensor must be dry during this process.

> You will be prompted to immerse the sensor into the calibration medium (ambient air).

Confirm this dialog with (**ON/OFF**). The currently measured values will be displayed.
 If the measured values (O₂+ Temperature) are in a stable condition, reconfirm by pressing (**ON/OFF**).

Via (**CONF +1**) or (**LOG -1**) you selected the desired setting.
(ON/OFF) confirms and saves your setting.
(MEAS) terminates the entry dialog without transferring the value.



This completes the calibration process. The new calibration value will be saved in the device.

 If the calibration is faulty, an error message will be displayed (see  **8.6.2.5**).

8.6.2.5 Calibration error

The limits for all calibration values are saved in the meter. If the entered values are outside these limits, one of the following error messages will be displayed:

"!Incorrect entry!" or **"!Calibration error!"**.

 You may have to repeat the calibration, service the sensor (see  chapter **12** "Maintenance set Z 615") or replace it (wear part!).

9 Meter Lab 845

9.1 Areas of use

The pH/ORP/ISE meter is used to determine the pH value, the chain tension as well as the temperature. The meter simultaneously measures the pH value, the chain tension and the temperature. The Lab845 combines the advantages of a compact design with the precision and comfort of a lab meter with a high measuring accuracy, multi-function display, integrated data logger and a robust aluminum housing.

9.2 Basic model

The basic model of the meter includes a pH sensor. This combination meets the requirements to determine the pH value; electro-chemical process as per EN ISO 10523:2012. The meter can be used wherever you want to measure pH values, ORP potentials or ISE concentrations as well as temperature quickly and precisely. High measuring accuracy, processor-controlled measured value processing and the versatility in connection with pH, ORP or ISE measuring chains mark the Lab845. It is equipped with automatic temperature compensation for pH measurement as well as an adjustable reference temperature for measurements taken without a temperature sensor. In addition to the value input, an automatic as well as a manual calibration routine is available to calibrate the meter. If an ORP single rod measuring chain is connected, the temperature-compensated and calculated ORP potential with reference to the standard hydrogen electrode as per DIN 38404 is displayed in addition to the measured ORP potential.

9.3 pH sensor

The description of the used pH electrode is listed in the separate instructions for use for the sensor.

9.4 Menu structure (CONF) Lab 845

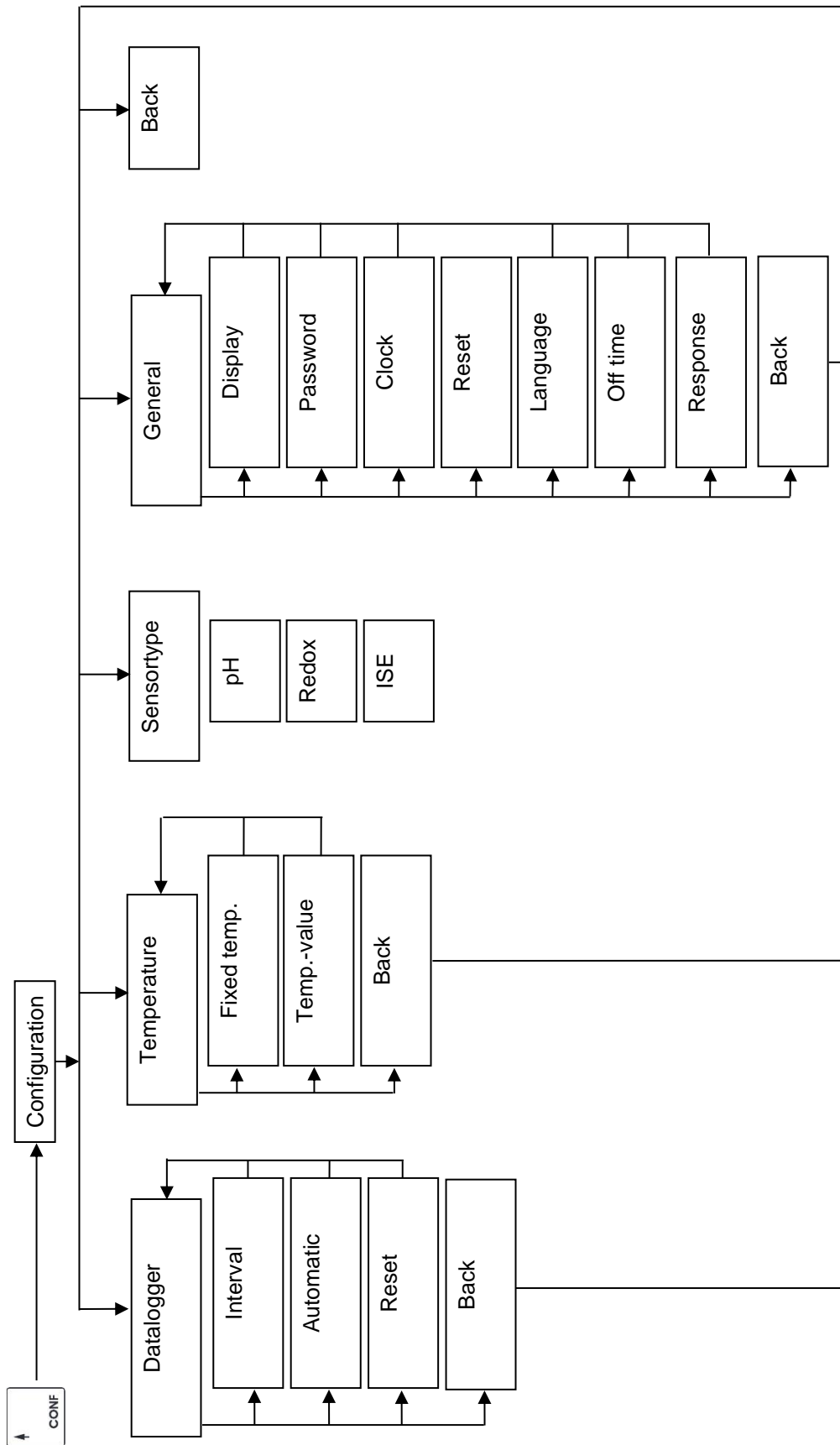



9.5 Configuration Lab 845

9.5.1 Basic settings

Via (**CONF**) you will go to the menu item "**Configuration**".

 The entire structure of the menu (**CONF**) is displayed graphically in  **9.4**.

The following device-relevant basic settings can be configured:

data logg.	→	Data logger ( Chapter 5)
temperature	→	Temperature
Sensortype	→	Sensortype
general.	→	General ( Kapitel 4)

9.5.2 Configuration of the fixed temperature

As the pH measured value is always temperature-compensated, the temperature of the measuring and calibration media must be measured or set up as a fixed temperature.

 If the fixed temperature is activated, it is used for temperature compensation.

> The message "**FIX**" will appear in the top right side of the display.

> Configuration of the fixed temperature:

"**Temperature**" > "**Fixed temperature**" >, then select **activate** / **deactivate**.

"**Temperature**" > "**Temp. value**" >, then select the fixed temperature value.

Via (**INFO**) or (**CAL**) you select the position to change.

Via (**CONF +1**) or (**LOG -1**) you change the position.

(**ON/OFF**) confirms and saves your setting.

(**MEAS**) terminates the entry dialog without transferring the value.

9.5.3 Configuration of the sensor type

3 different sensor types can be connected to the Lab 845.

pH
ORP
ISE

Sensor selection:

Select "**Sensor type**" >, then **Type**.

Via (**CONF +1**) or (**LOG -1**) you selected the desired setting.

(**ON/OFF**) confirms and saves your setting.

(**MEAS**) terminates the entry dialog without transferring the value.

9.6 Calibration method pH

9.6.1 Menu structure

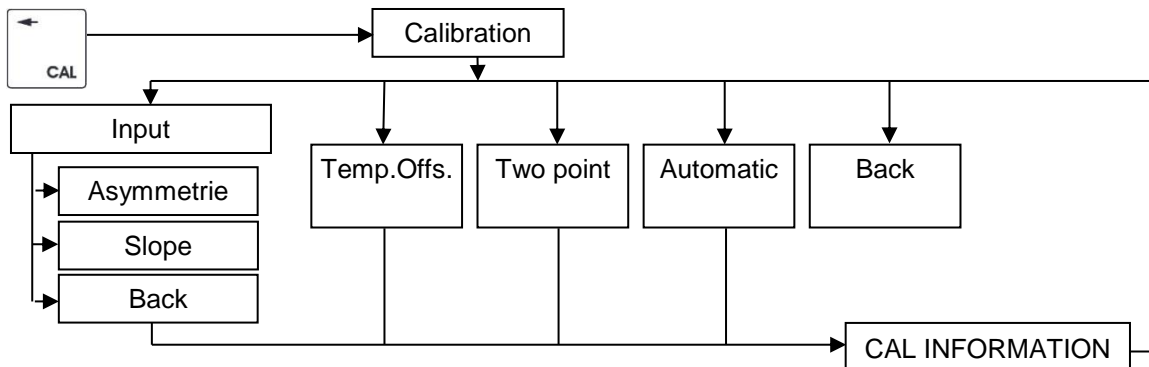

9.6.2 Calibration

Select **(CAL)** to get to the menu item "**Calibration**" and then on to the **Calibration menu**:

> The calibration procedures for the respective sensor type are displayed.

Choose your desired calibration procedure by selecting the respective menu item.

⚠ The sensor must be thoroughly cleaned with distilled or deionized water prior to and between every measurement.

Immerse the sensor into the calibration solution and wait until a stable measured value is reached.

i Ensure that the calibration medium is mixed properly and watch for the temperature balance.

9.6.2.1 Data input

Under menu item "**Input**", you can enter and change the specific characteristics of the connected sensor, e.g. ones that were previously defined in the lab, individually.

> For this, select the respective submenu item for which the settings should be changed (**Asymmetry, Steepness**).

An input dialog will allow you to change the respective calibration/sensor values and their respective limits. If these are not reached or exceeded, there will be an error message, which will ask you to enter a value within these limits.

Via **(INFO)** or **(CAL)** you select the position to change.

Via **(CONF +1)** or **(LOG -1)** you change the position.

(ON/OFF) confirms and saves your setting.

(MEAS) terminates the entry dialog without transferring the value.

9.6.2.2 Temperature offset

Under menu item "**Temp.Offs.**" you can enter an offset for the temperature value.

> Select "**Temp.Offs.**".

An input dialog allows you to set up the offset. This value can be positive or negative.

Via **(CONF +1)** or **(LOG -1)** you change the position.

(ON/OFF) confirms and saves your setting.

(MEAS) terminates the entry dialog without transferring the value.

9.6.2.3 Two point calibration

> You will be prompted to immerse the sensor into the *first calibration medium* (ambient air).

Confirm this dialog with **(ON/OFF)**. The currently measured values will be displayed.
If the measured values (pH + temperature!) are in a stable condition, reconfirm by pressing **(ON/OFF)**.

> You will be prompted to enter a nominal value (temperature-corrected buffer value!).

Via **(INFO)** or **(CAL)** you select the position to change.

Via **(CONF +1)** or **(LOG -1)** you change the position.

(ON/OFF) confirms and saves your setting.

(MEAS) terminates the entry dialog without transferring the value.

> You will be prompted to immerse the sensor into the *second calibration medium*.

Perform the same steps as with the first calibration solution

9.6.2.4 Automatic calibration

The automatic calibration of the pH measurement is a two point calibration and requires the knowledge, which buffer solutions you would like to use for the calibration.

The Lab 845 offers the following buffer sets for the calibration:

NBS standard buffering solution as per DIN 19266: pH value at 25 °C 1.68 / 4.01 / 6.86 / 9.18 / 12.45

Technical buffering solution as per DIN 19267: pH value at 25 °C 1.09 / 3.06 / 4.65 / 6.79 / 9.23

Merck buffering solution: pH value at 20 °C 4.00 / 7.00 / 9.00

Mettler Toledo buffering solution: pH value at 25 °C 1.679 / 4.003 / 7.002 / 10.013

> Select the buffer set you would like to use for the calibration.

You will be prompted to immerse the sensor into the *first calibration solution*.

Confirm this dialog with **(ON/OFF)**. The currently measured values will be displayed.
If the measured values (pH + temperature!) are in a stable condition, reconfirm by pressing **(ON/OFF)**. The found buffer will be displayed, reconfirm with **(ON/OFF)**.

Immerse the sensor into the *second calibration solution*.

Perform the same steps as with the first calibration solution.

This completes the calibration process. The new calibration value will be saved in the device.

 If the calibration is faulty, an error message will be displayed (see  **9.6.2.5**).

9.6.2.5 Calibration error

The limits for all calibration values are saved in the meter. If the entered values are outside these limits, one of the following error messages will be displayed:

"!Incorrect entry!" or **"!Calibration error!"**.

 You may have to repeat the calibration, service the sensor or replace it (wear part!).

9.7 Calibration method OPR

9.7.1 Menu structure

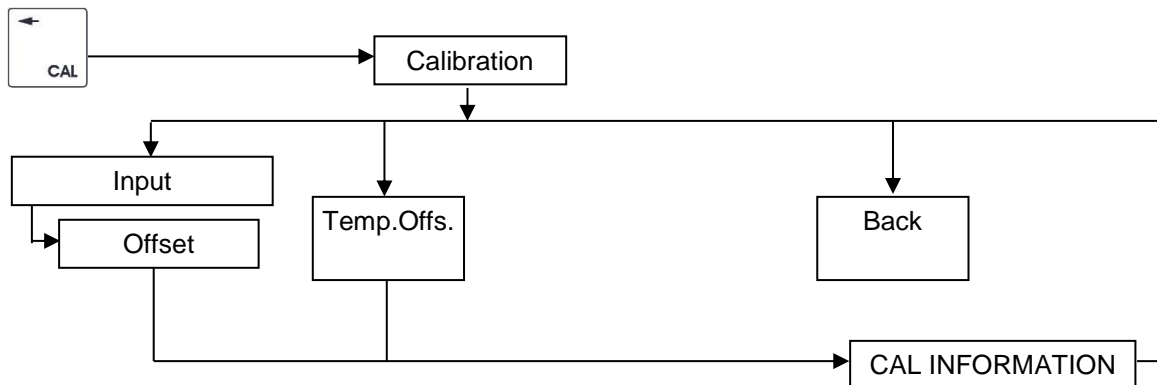

9.7.2 Calibration

Select (CAL) to get to the menu item "Calibration" and then on to the **Calibration menu**:

> The calibration procedures for the respective sensor type are displayed.

Choose your desired calibration procedure by selecting the respective menu item.

⚠ The sensor must be thoroughly cleaned with distilled or deionized water prior to and between every measurement.
Immerse the sensor into the calibration solution and wait until a stable measured value is reached.

i Ensure that the calibration medium is mixed properly and watch for the temperature balance.

9.7.2.1 Data input

Under menu item "**Input**" you can enter an offset for the ORP potential.

Via (INFO) or (CAL) you select the position to change.

Via (CONF +1) or (LOG -1) you change the position.

(ON/OFF) confirms and saves your setting.

(MEAS) terminates the entry dialog without transferring the value.

9.7.2.2 Temperature offset

Under menu item "**Temp.Offs.**" you can enter an offset for the temperature value.

> Select "**Temp.Offs.**".

An input dialog allows you to set up the offset. This value can be positive or negative.

Via (CONF +1) or (LOG -1) you change the position.

(ON/OFF) confirms and saves your setting.

(MEAS) terminates the entry dialog without transferring the value.

9.8 Calibration method ISE

9.8.1 Menu structure

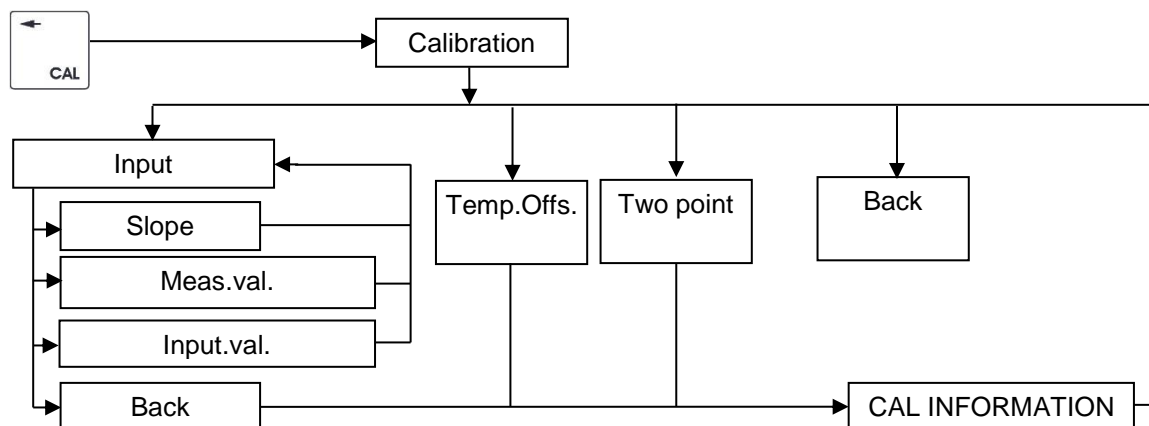

9.8.2 Calibration

Select (CAL) to get to the menu item "Calibration" and then on to the **Calibration menu**:

> The calibration procedures for the respective sensor type are displayed.

Choose your desired calibration procedure by selecting the respective menu item.

⚠ The sensor must be thoroughly cleaned with distilled or deionized water prior to and between every measurement.

Immerse the sensor into the calibration solution and wait until a stable measured value is reached.

i Ensure that the calibration medium is mixed properly and watch for the temperature balance.

9.8.2.1 Data input

Under menu item "Input", you can enter and change the specific characteristics of the connected sensor, e.g. ones that were previously defined in the lab, individually.

> Select the respective submenu item for which the settings should be changed (**Asymmetry, measured value 1, input value 1**).

An input dialog will allow you to change the respective calibration/sensor values and their respective limits. If these are not reached or exceeded, there will be an error message, which will ask you to enter a value within these limits.

Via (INFO) or (CAL) you select the position to change.

Via (CONF +1) or (LOG -1) you change the position.

(ON/OFF) confirms and saves your setting.

(MEAS) terminates the entry dialog without transferring the value.

9.8.2.2 Temperature offset

Under menu item "**Temp.Offs.**" you can enter an offset for the temperature value.

> Select "**Temp.Offs.**".

An input dialog allows you to set up the offset. This value can be positive or negative.

Via (**CONF +1**) or (**LOG -1**) you selected the desired setting.

(**ON/OFF**) confirms and saves your setting.

(**MEAS**) terminates the entry dialog without transferring the value.

9.8.2.3 Two point calibration

> You will be prompted to immerse the sensor into the *first calibration medium* (ambient air).

Confirm this dialog with (**ON/OFF**). The currently measured values will be displayed.
If the measured values (conductivity + temperature!) are in a stable condition,
reconfirm by pressing (**ON/OFF**).

> You will be prompted to enter a nominal value (temperature-corrected buffer value!).

Via (**INFO**) or (**CAL**) you select the position to change.

Via (**CONF +1**) or (**LOG -1**) you change the position.

(**ON/OFF**) confirms and saves your setting.

(**MEAS**) terminates the entry dialog without transferring the value.

> You will be prompted to immerse the sensor into the *second calibration medium*.

Perform the same steps as with the first calibration solution

10 Meter Lab 945

10.1 Areas of use

The Lab 945 is used to determine electrical conductivity, salinity and temperature and combines the advantages of a compact design with the precision and comfort of a lab meter. Simultaneous conductivity, salinity and temperature measurement, high measurement accuracy, multi-functional display, integrated data logger and a robust aluminum housing mark this meter.

10.2 Basic model

The basic model of the meter Lab945 includes the conductivity sensor LF435T. This combination meets the requirements to determine the conductivity; electro-chemical process as per EN 27888:1993. When connected to the sensor, the meter will capture the conductivity in μS or mS , the temperature as well as the salinity simultaneously.

10.3 Conductivity sensor LF435T

The 4-pin sensor LF435T is very suitable for the universal applications in a lab. Two parallel, mostly contamination-resistant graphite electrodes, the integrated temperature sensor for parallel temperature measurement and automatic temperature compensation as well as the extended measuring range mark this sensor.

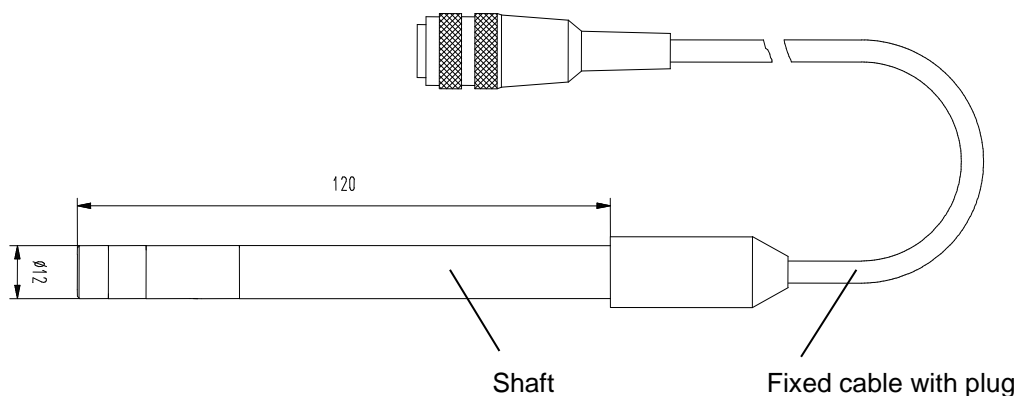

10.4 Menu structure (CONF) Lab 945

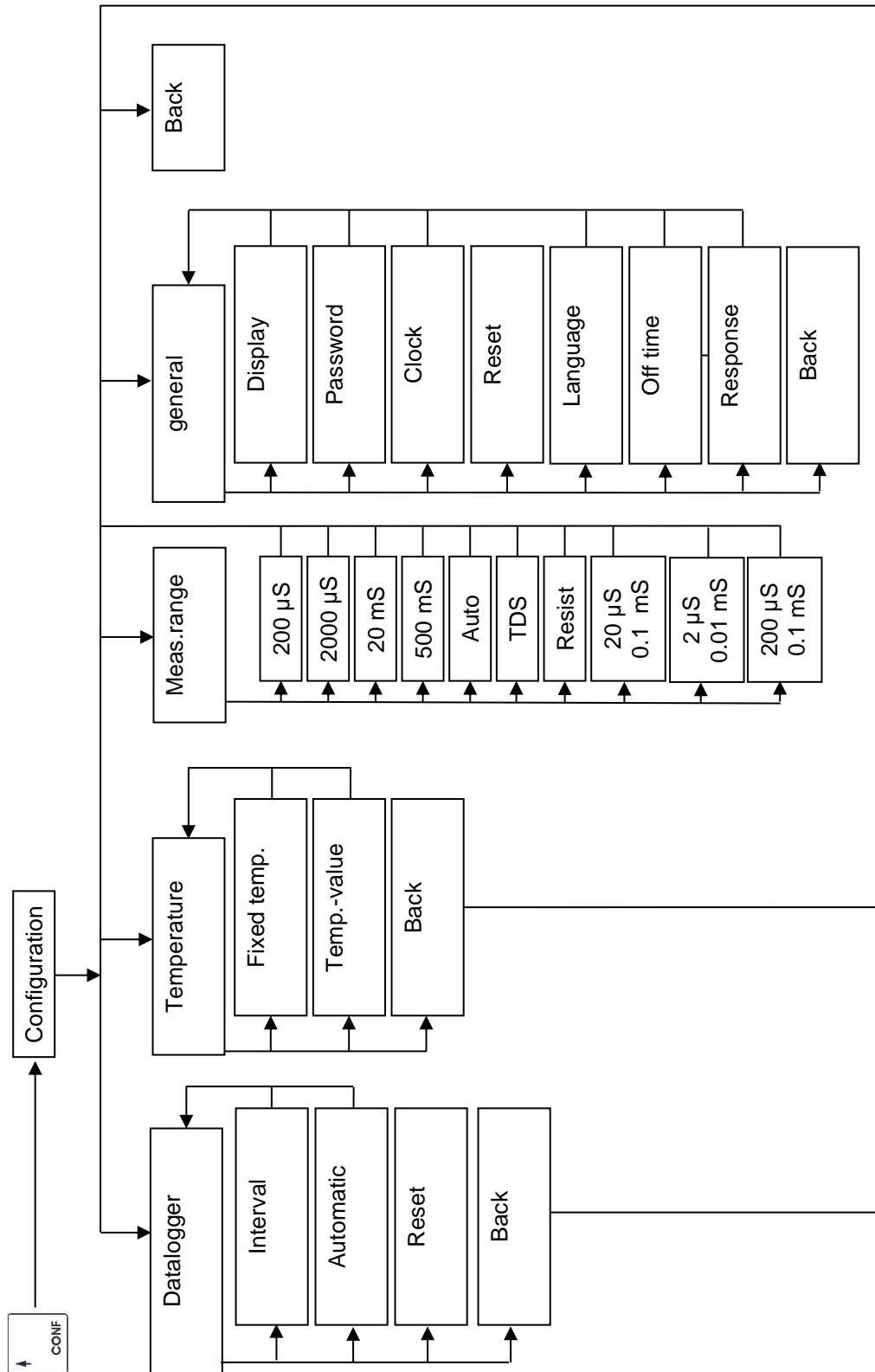



10.5 Configuration Lab 945

10.5.1 Basic settings

Via (**CONF**) you will go to the menu item "**Configuration**".

 The entire structure of the menu (**CONF**) is displayed graphically in  **10.4**.

The following device-relevant basic settings can be configured:

data logg.	→	Data logger ( Chapter 5)
temperature	→	Temperature
main value	→	main value
general.	→	General ( Kapitel 4)

10.5.2 Configuration of the fixed temperature

The measured conductivity value can be put out temperature-compensated. For this, the temperature of the measuring and calibration media must be measured or set up as a fixed temperature.

 If the fixed temperature is activated, it is used for temperature compensation.

> The message "**FIX**" will appear in the top right side of the display.

> Configuration of the fixed temperature:

"**Temperature**" > "**Fixed temperature**" >, then select **activate** / **deactivate**.

"**Temperature**" > "**Temp. value**" >, then select the fixed temperature value.

Via (**INFO**) or (**CAL**) you select the position to change.

Via (**CONF +1**) or (**LOG -1**) you change the position.

(**ON/OFF**) confirms and saves your setting.

(**MEAS**) terminates the entry dialog without transferring the value.

10.5.3 Configuration of the measuring range "M range"

> Configuration of the measuring range:

First select the "**M range**">, then the measuring range.

The measuring range has 7 settings on the meter.

Measuring range	Main measured variable	Secondary measured variable
200 μ S ¹⁾	LF	Saline
2000 μ S ¹⁾	LF	Saline
20mS ¹⁾	LF	Saline
500mS ¹⁾	LF	Saline
20 μ S ^{2) 3)}	LF	Resist
2 μ S ^{2) 4)}	LF	Resist
200 μ S ^{2) 3)}	LF	Resist

Auto > automatically selects the suitable measuring range

TDS⁵⁾ > shows the TDS value as a secondary variable

Resist.⁵⁾ > shows the resistance value as a secondary variable

¹⁾ Measuring range switching possible

²⁾ Measuring range switching requires a special sensor (measuring ranges are purest water).
This sensor must be ordered separately.

³⁾ Used cell constant 0,1 cm⁻¹

⁴⁾ Used cell constant 0,01 cm⁻¹

⁵⁾ Measuring range switching also takes place automatically

Via (**CONF +1**) or (**LOG -1**) you selected the desired setting.

(**ON/OFF**) confirms and saves your setting.

(**MEAS**) terminates the entry dialog without transferring the value.

10.6 Calibration method Conductivity

10.6.1 Menu structure

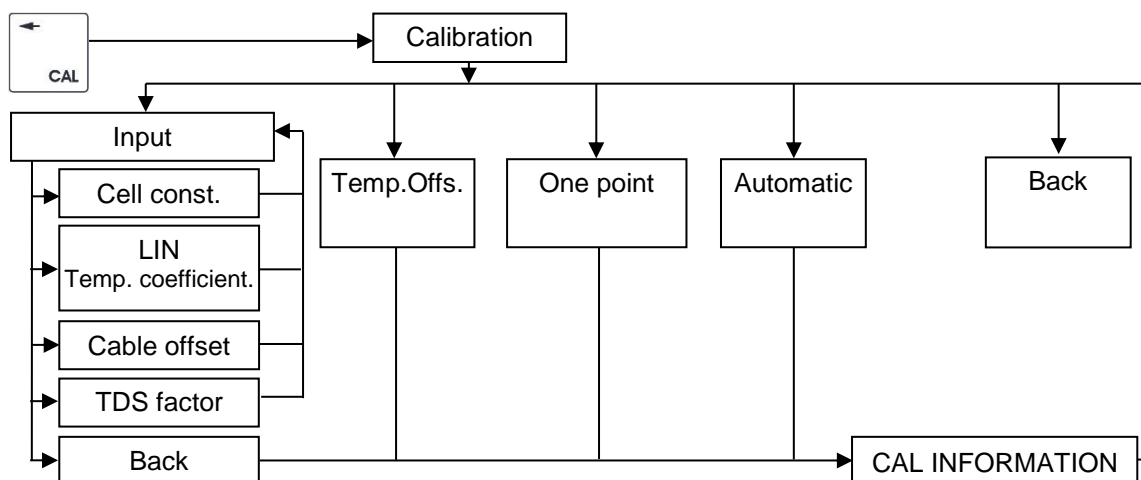

10.6.2 Calibration

Select **(CAL)** to get to the menu item "**Calibration**" and then on to the **Calibration menu**:

> The calibration procedures for the respective sensor type are displayed.

Choose your desired calibration procedure by selecting the respective menu item.

⚠ The sensor must be thoroughly cleaned with distilled or deionized water prior to and between every measurement.

Immerse the sensor into the calibration solution and wait until a stable measured value is reached.

i Ensure that the calibration medium is mixed properly and watch for the temperature balance.

10.6.2.1 Data input

Under menu item "**Input**", you can enter and change the specific characteristics of the connected sensor, e.g. ones that were previously defined in the lab, individually.

> Select the respective submenu item for which the settings should be changed.

Zellkonst.	→	Cell constant
nLF/LIN Tempkoef.	→	Temperature compensation + temperature coefficient
Kabeloffset.	→	Cable offset
TDS Faktor	→	TDS factor

An input dialog will allow you to change the respective calibration/sensor values and their respective limits. If these are not reached or exceeded, there will be an error message, which will ask you to enter a value within these limits.

The temperature compensation can be set as follows:

Lin:	Linear temperature compensation with adjustable temperature coefficient
nLF:	non-linear temperature compensation (for natural waters as per DIN EN 27888)
out:	For measurements without temperature compensation, the temperature coefficient must be set to "0 %/K" under LIN.

Via **(INFO)** or **(CAL)** you select the position to change.

Via **(CONF +1)** or **(LOG -1)** you change the position.

(ON/OFF) confirms and saves your setting.

(MEAS) terminates the entry dialog without transferring the value.

10.6.2.2 Temperature offset

Under menu item "**Temp.Offs.**" you can enter an offset for the temperature value.

> Select "**Temp.Offs.**".

An input dialog allows you to set up the offset. This value can be positive or negative.

Via (**CONF +1**) or (**LOG -1**) you selected the desired setting.

(**ON/OFF**) confirms and saves your setting.

(**MEAS**) terminates the entry dialog without transferring the value.

10.6.2.3 One point calibration

The measuring signal will be calibrated at this one point by means of a defined calibration solution or with a known nominal value, e.g. via an independent procedure or a lab/field device.

> Sie werden aufgefordert, den Sensor in das Kalibriermedium zu tauchen.

Confirm this dialog with (**ON/OFF**). The currently measured value is displayed.

If the measured value is in stable condition, reconfirm the dialog box with (**ON/OFF**).

> You will be prompted to enter a nominal value.

Via (**CONF +1**) or (**LOG -1**) you selected the desired setting.

(**ON/OFF**) confirms and saves your setting.

(**MEAS**) terminates the entry dialog without transferring the value.

This completes the calibration process. The new calibration value will be saved in the device.

10.6.2.4 Automatic calibration

The automatic calibration of the conductivity sensor is a one point calibration with automatic buffer detection.

The following conductivity calibrations are archived:

0.01 N KCl: 1.41 mS/cm (25 °C)



0.1 N KCl: 12.9 mS/cm (25 °C)

> You will be prompted to immerse the sensor into the calibration medium.

Confirm this dialog with (**ON/OFF**). The currently measured values will be displayed.

If the measured values (conductivity + temperature!) are in a stable condition, reconfirm by pressing (**ON/OFF**).

This completes the calibration process. The new calibration value will be saved in the device.

 If the calibration is faulty, an error message will be displayed (see  **10.6.2.5**).

10.6.2.5 Calibration error

The limits for all calibration values are saved in the meter. If the entered values are outside these limits, one of the following error messages will be displayed:

"!**Incorrect entry!**" or "**!Calibration error!**".

 You may have to repeat the calibration, service the sensor or replace it (wear part!).

11 Scope of delivery

Lab 745 Set	Lab oxygen meter Power supply Tripod Oxygen measuring cell Ox1113T
Lab 845 Set/BL19pH	Lab pH meter Power supply Tripod BlueLine 19 pH DIN buffer in ampules (6 ea.)
Lab 845 Set/BL25pH	Lab pH meter Power supply Tripod BlueLine 25 pH DIN buffer in ampules (6 ea.)
Lab 845 Set/BL29pH	Lab pH meter Power supply Tripod BlueLine 29 pH DIN buffer in ampules (6 ea.)
Lab 945 Set/LF435T	Lab conductivity meter Power supply Tripod Conductivity measuring cell LF435T Conductivity testing solutions in ampules (6 ea.)
Lab 945 Set/LF513T	Lab conductivity meter Power supply Tripod Conductivity measuring cell LF513T Conductivity testing solutions in ampules (6 ea.)
Lab 945 Set/LF613T	Lab conductivity meter Power supply Tripod Conductivity measuring cell LF613T Conductivity testing solutions in ampules (6 ea.)

12 Accessories

Tripod set with Electrode holder Z 611	adapter, rod and electrode holder for Lab 745/845/945
Power supply Z 612	Extended range power supply for Lab 745/845/945
Connecting cable Z 613	USB cable with data transfer software for Lab 745/845/945
Replacement legs Z 613	4 ea. for 745/845/945
Oxygen electrode Ox 1113T	Membrane covered amperometric sensor, plastic shaft, with temperature compensation, 1½ m fixed cable with 8-pin plug, length 120 mm, 12 mm diameter, -5...+45 °C
Conductivity measuring cell with fixed cable LF 435T	4-pin measuring cell, plastic shaft, 1.5 m cable with 8-pin plug, sensor material graphite, cell constant 0.33 cm ⁻¹ , Temp.-sensor NTC 30 kOhm, length 120 mm, 12 mm Ø, -5...+80 °C
Maintenance set Z615	for Ox1113T(3 x replacement head, 10 x electrolyte)
Connecting cable	to connect an RS232 printer to the Lab 745/845/945

13 Maintenance

 **The meter must never be cleaned with an aggressive solvent (such as acetone)!**

 **Do not use stiff brushes or metal objects!**

 Wipe the meter down with a moist, lint-free cloth every once in a while.

 For the maintenance and storage of the sensors and fittings to be connected, the notes and regulations in the respective instructions and data sheets apply.

14 Guarantee

We provide guarantee for the device described for two years from the date of purchase. This guarantee covers manufacturing faults being discovered within the mentioned period of two years. Claim under guarantee covers only the restoration of functionality, not any further claim for damages or financial loss. Improper handling/use or illegitimate opening of the device results in loss of the guarantee rights. The guarantee does not cover wear parts. The breach of glass parts is also excluded. To ascertain the guarantee liability, please return the instrument and proof of purchase together with the date of purchase freight paid or prepaid.

15 Recycling and Disposal

The meter Lab 745 / 845 / 945 and his packaging are manufactured as far as possible from materials which can be disposed of environmental-friendly and recycled in a technically appropriate manner.



Please note: The main printed board carries a lithium battery. Batteries should not to be disposed of with the normal domestic waste. They will be taken back and recycled or disposed of properly by the manufacturer at no cost.

If you have any question regarding disposal, please contact SI Analytics.

SI Analytics®

EG - KONFORMITÄTSERKLÄRUNG EC - DECLARATION OF CONFORMITY CE - DÉCLARATION DE CONFORMITÉ CEE - DECLARACIÓN DE CONFORMIDAD

Wir erklären in alleiniger Verantwortung, dass die folgenden Produkte	We declare under our sole responsibility that the following products	Nous déclarons sous notre seule responsabilité que les produits ci-dessous	Declaramos bajo nuestra única responsabilidad, que los productos listados a continuación
Sauerstoff-Messgerät	Oxygen-meter	Oxygène-mètre	Oxygène-metro
Lab 745			
pH-mV-Messgerät	pH-mV-meter	pH-mV-mètre	pH-mV-metro
Lab 845			
Leitfähigkeits-Messgerät	Conductivity-meter	Conductivity-mètre	Conducti-metro
Lab 945			
auf die sich diese Erklärung bezieht, übereinstimmen mit den folgenden EG Richtlinien	to which this declaration relates are in conformity with the following EC directives	auquel se réfère cette déclaration est conforme directives CE soul vantes	todo lo relative a esta declaración está en conformidad con las directivas CEE siguientes
EMV EG-Richtlinie 2004/108/EG Sicherheit EG Richtlinie 2006/ 95/EG	EMC EC-Directive 2004/108/EG Safety EC-Directive 2006/ 95/EG	CEM CE-Directive 2004/108/EG Sécurité CE-Directive 2006/ 95/EG	CEM CEE siguientes 2004/108/EG Seguridad CEE siguientes 2006/ 95/EG
Angewandte harmonisierte Normen oder normative Dokumente	Applied harmonized standards or normative documents	Normes harmonisées ou documents normative appliquées	Estándares armonizados aplicados o documentos normativos
EMV EN 61326-1:2013 Sicherheit EN 61010-1 :2010	EMC EN 61326-1:2013 Safety EN 61010-1 :2010	CEM EN 61326-1:2013 Sécurité EN 61010-1 :2010	CEM EN 61326-1:2013 Seguridad EN 61010-1 :2010

Mainz den 18.01.2016

 Dr. Robert Reining
 Geschäftsführer, Managing Director

Konf. No.:pH 011

SI Analytics GmbH
 Hattenbergstr.10
 55122 Mainz
 Deutschland, Germany, Allemagne, Alemania

